

duotank

TANKBEER SYSTEMS

Compact Delivery Unit

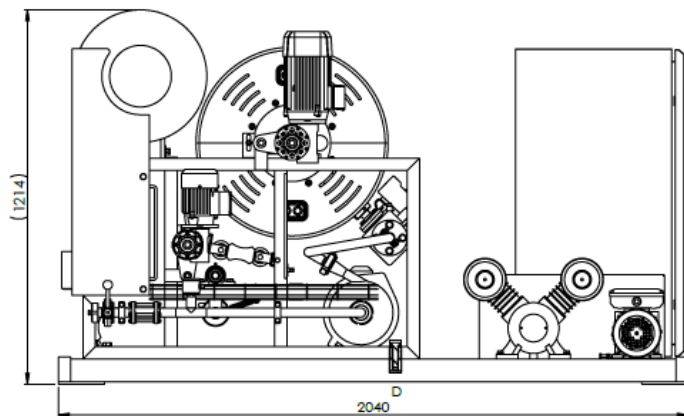

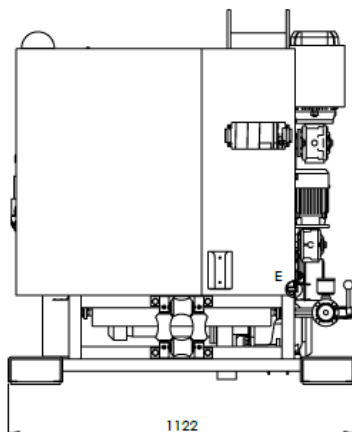
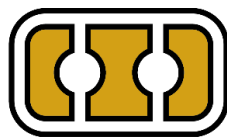

duotank

TANKBEER SYSTEMS

Compact Delivery Unit

Specifications & Options:	Standard CDU
Dimensions (lxwxh) mm	2040x1140x1203
Weight (kg)	~400 kg
Top frame for extra protection	o
Power connection	230 Volt / 16 Ampere
Electricity reel with spring retraction system 50 metre	✓
Autonomous battery energy system	o
Beer reel	Controlled with hose guide
Remote control	✓
Torque operated automatic unwinding system	o
Beer hose	Duotank 60 metres DN25
Beer hose connection	DN25
Other beer hose connection	o
Compressor	1,1 kW Duotank HVLP
1,1 kW Atlas Copco LFX with 2x100 Litre Aluminium tanks and air conditioning system	o
Pump	1,1 kW centrifugal pump
Flowmeter	✓
Accuracy	< 0.25% on deliveries > 20 l/m
MID certificate	✓
Touchscreen	9 Inch Simatic
Controller	Siemens S7
Printer (TM-T70)	✓
CSV Module for beer quality traceability	o
Cloud connection over MQTT to API or DSO system*	o

Standard	✓
Option	o
Option not available	N